

Unequal angles

Laser fused - Saldato Laser

A	B	t	kg/m
30	20	3	1.15
30	20	4	1.49
40	20	3	1.39
40	20	4	1.82
40	20	5	2.23
40	25	5	2.40
40	30	3	1.63
40	30	4	2.14
40	30	5	2.60
45	30	3	1.77
45	30	4	2.31
45	30	5	2.84
45	30	6	3.31
50	15	5	2.40
50	30	3	1.89
50	30	4	2.47
50	30	5	3.00
50	30	10	5.60
50	35	4	2.59
50	35	8	4.93
50	40	3	2.13
50	40	4	2.75
50	40	5	3.44
50	40	10	6.40
50	45	5	3.60
60	30	5	3.40
60	30	6	4.03
60	30	7	4.65
60	40	5	3.80
60	40	6	4.51
60	40	8	5.89
65	50	5	4.4
65	50	6	5.23
65	50	7	6.05

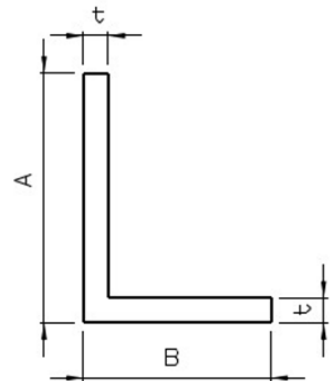

Dimensional Tolerances

Tolleranze dimensionali

EN 10056-2

Available materials

Qualità disponibili

AISI 304/W.1.4301

AISI 304L/W.1.4307

AISI 316/W.1.4401

AISI 316L/W.1.4404

AISI 316Ti/W.1.4571

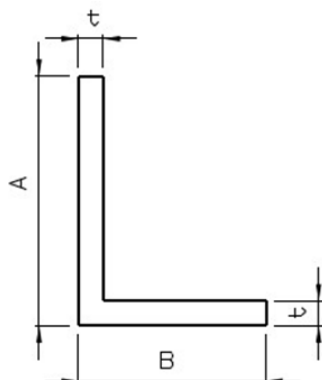

Dimensional Tolerances

Tolleranze dimensionali

EN 10056-2

Available materials

Qualità disponibili

AISI 304/W.1.4301

AISI 304L/W.1.4307

AISI 316/W.1.4401

AISI 316L/W.1.4404

AISI 316Ti/W.1.4571

A	B	t	kg/m
65	50	8	6.85
65	50	9	7.63
70	50	5	4.60
70	50	6	5.47
70	50	7	6.33
70	50	8	7.17
70	50	9	8
70	50	10	8.80
75	50	6	5.71
75	50	7	6.61
75	50	8	7.49
75	50	10	9.20
75	55	6	5.96
75	55	7	6.89
75	55	8	7.81
75	55	9	8,72
80	20	5	3.80
80	40	5	4.60
80	40	6	5.47
80	40	6	5,48
80	40	8	7.17
80	40	10	8.80
80	60	7	7.45
80	60	8	8.45
80	65	6	6.67
80	65	8	8.77
80	65	10	10.80
80	65	12	12.77
90	60	6	6.91
90	60	8	9.09
95	45	12	6.40
100	40	12	12.29
100	50	4	4.67
100	50	5	5.80
100	50	6	6.91
100	50	8	9.09
100	50	10	11.20
100	50	12	13.25
100	65	6	7.63
100	65	7	8.85

UNEQUAL ANGLES LASER FUSED

A	B	t	kg/m
100	65	8	10.05
100	65	9	11.23
100	65	10	12.40
100	65	11	13.55
100	75	6	8.11
100	75	7	9.41
100	75	8	10.69
100	75	9	11.95
100	75	10	13.20
100	75	12	15.65
100	80	8	11.01
110	60	10	12.80
120	60	6	8.35
120	65	10	14.00
120	80	6	9.31
120	80	8	12.29
120	80	10	15.20
120	80	12	18.05
125	75	7	10.81
125	75	10	15.20
125	75	12	18.05
125	80	8	12.61
125	80	10	15.60
130	65	6	9.07
130	65	7	10.53
130	65	8	11.97
130	65	10	14.80
130	75	6	9.55
130	75	8	12.61
130	75	10	15.60
130	80	10	16.00
130	90	10	16.80
130	90	12	19.97
140	80	10	16.80
140	90	8	14.21
140	90	10	17.60
140	90	12	20.93
150	50	6	9.31
150	50	8	12.29
150	65	8	13.25

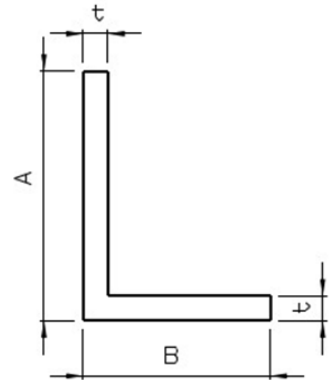

Dimensional Tolerances

Tolleranze dimensionali

EN 10056-2

Available materials

Qualità disponibili

AISI 304/W.1.4301

AISI 304L/W.1.4307

AISI 316/W.1.4401

AISI 316L/W.1.4404

AISI 316Ti/W.1.4571

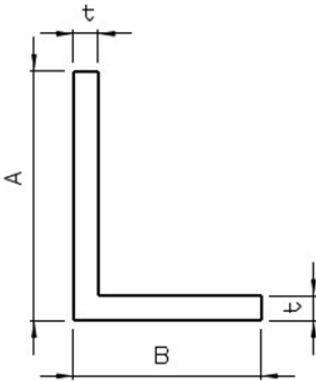

Dimensional Tolerances

Tolleranze dimensionali

EN 10056-2

Available materials

Qualità disponibili

AISI 304/W.1.4301

AISI 304L/W.1.4307

AISI 316/W.1.4401

AISI 316L/W.1.4404

AISI 316Ti/W.1.4571

A	B	t	kg/m
150	75	6	10.51
150	75	8	13.89
150	75	10	17.20
150	75	11	18.83
150	75	12	20.45
150	75	15	25.20
150	90	8	14.85
150	90	9	16.63
150	90	10	18.40
150	90	11	20.15
150	90	12	21.89
150	90	15	27.00
150	100	8	15.49
150	100	10	19.20
150	100	12	22.85
150	100	15	28.20
150	140	10	22.40
160	50	10	16.00
160	65	8	13.89
160	80	8	14.85
160	80	10	18.40
160	80	12	21.89
160	80	15	27.00
160	100	8	16.13
160	100	10	20.00
160	100	12	23.81
180	90	8	16.77
180	90	10	20.80
180	90	12	24.77
200	75	6	12.91
200	80	8	17.41
200	100	8	18.69
200	100	10	23.20
200	100	12	27.65
200	100	13	29.85
200	100	15	34.20
200	100	16	36.35
200	120	12	29.57
200	150	12	32.45
200	150	15	40,2
250	75	10	25,2
250	100	10	27,2
250	150	15	46,2
350	150	15	58,2